



GB

- Efficient filter unit with compressed air
- Equipped with fan type VL 1150, 1.10 kW
- Max. fan vacuum in standard version: 2,000Pa
- Equipped with motor protection
- Delivered standard with filter cartridge G105, dust class M
- Standard equipped with extraction arm type SA or RGF (excl. damper in hood)
- Extraction arm can rotate 360°
- Spark arrest
- Compressed-air cleaning with control
- 2 pcs. cables with plug (230VAC)
- Cejn compressed-air coupling
- Suitable for extraction air recirculation and therefore no application in Denmark (DK)

D

- Effiziente Filtereinheit mit Druckluft
- Ausgestattet mit Ventilator Typ VL 1150, 1,10 kW
- Max. Ventilator-Vakuum in Standard-Ausführung: 2.000Pa
- Ausgestattet mit Motorschutz
- Wird Standard mit Filterpatrone G105, Staubklasse M, geliefert
- Standard mit Punktabaugarm Typ SA oder RGF (ausschl. Klappe im Trichter) ausgerüstet
- Punktabaugarm kann 360° drehen
- Funkenfang
- Druckluft-Reinigung mit Steuerung
- 2 Stck. Kabel mit Stecker (230VAC)
- Cejn-Druckluftkupplung
- Geeignet für Rezirkulation von abgeseugter Luft und darf deshalb in Dänemark (DK) nicht verwendet werden

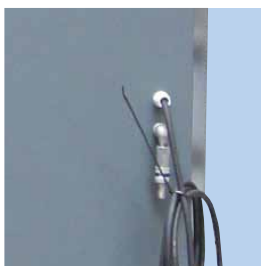

Compressed-air
Easy access to compressed-air connection by Cejn-coupling. Pressure tank in unit.



Motor protection
Integrated motor protection.



Service
Easy service of dust container.

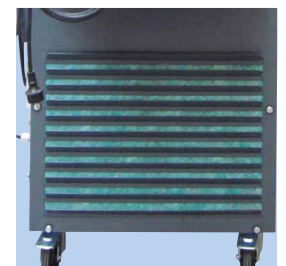

Outlet
Noise damped outlet with diffuse exhaust.

Colour/Farbe: RAL 5007/7011 (structure/Struktur)

V. Aa. Gram A/S

LYSBJERGVEJ 10 • HAMMELEV • DK-6500 Vojens
TELEPHONE +45 74 52 30 75 • TELEFAX +45 74 53 01 64
E-MAIL: info@vaagram.dk • INTERNET: www.vaagram.com



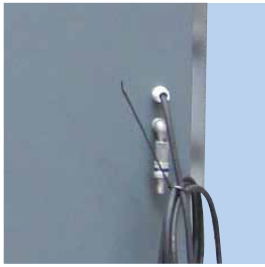

Druckluft
Einfacher Zugang zum Druckluft-Verbindung durch Cejn-Kupplung. Druckluftbehälter in der Anlage.



Motorschutz
Integrierter Motor-schutz.



Wartung
Einfache Wartung von Staubschublade.

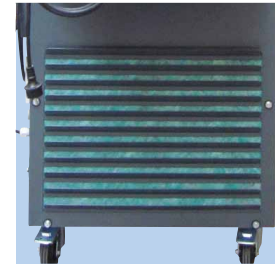

Abluft
Schallgedampfte Ab-luft mit diffussem Aus-blasen.

Mobile filter unit type SFPT:

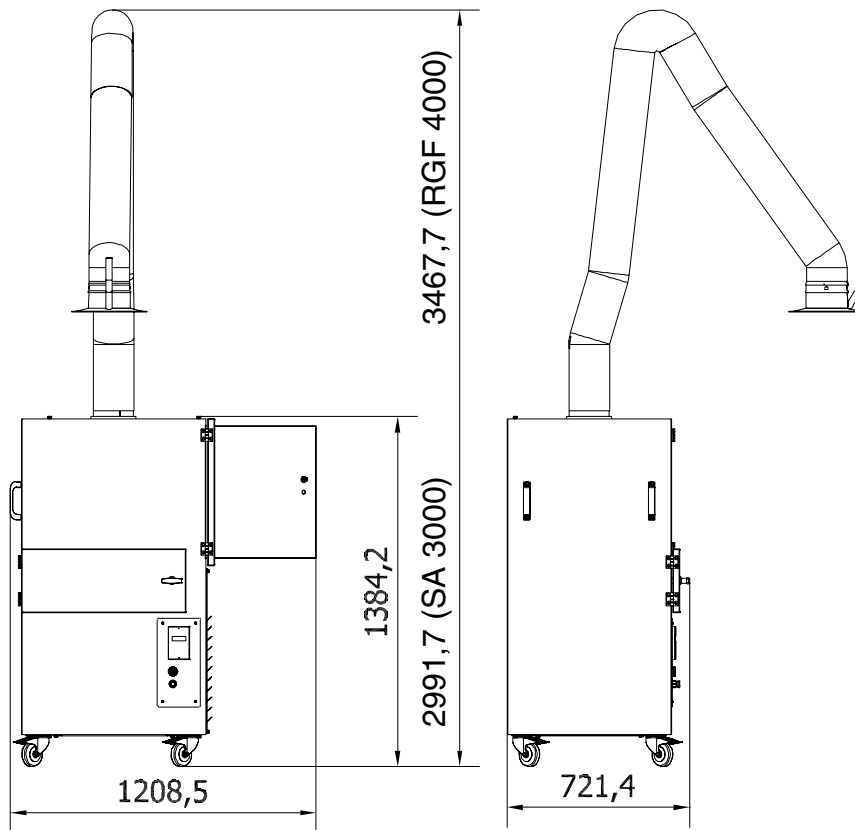

Type	Order no.	Fan	Motor [kW]	Voltage [V]	Arm type	Filter	Filter material*
SFPT1	04 142 600	VL 1150	1.10	1x230	SA 3000/ø160	1 x 21 m ²	G105
SFPT1	04 142 650	VL 1150	1.10	1x230	RGF 4000/ø160	1 x 21 m ²	G105

* Filter type: Jet filter cartridge ø325x660mm/ø13,5mm, 21m², G105 (08 128 000).
For other filter materials - see price list.

Recht auf Änderungen bleibt vorbehalten. / Data is subject to alterations.

Rev. 05-13



GB

Filter unit type SFPT for wall mounting

- Delivered inclusive wall fittings

D

Filteranlage Typ SFPT für Wandmontage

- Wird einschl. Wandbeschläge geliefert

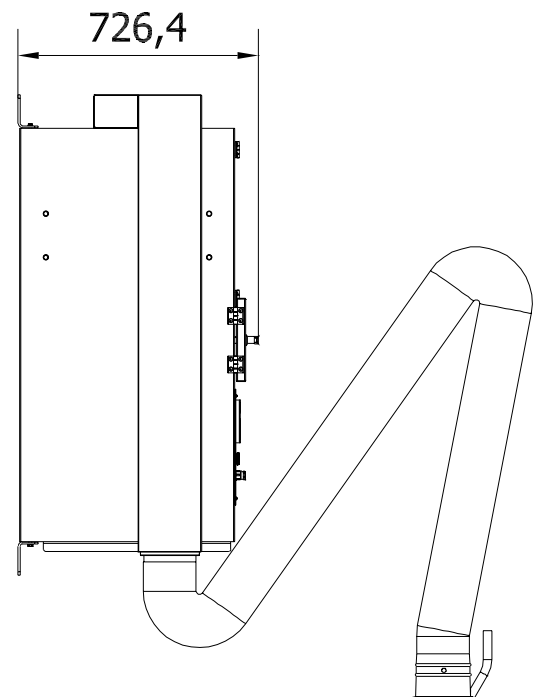
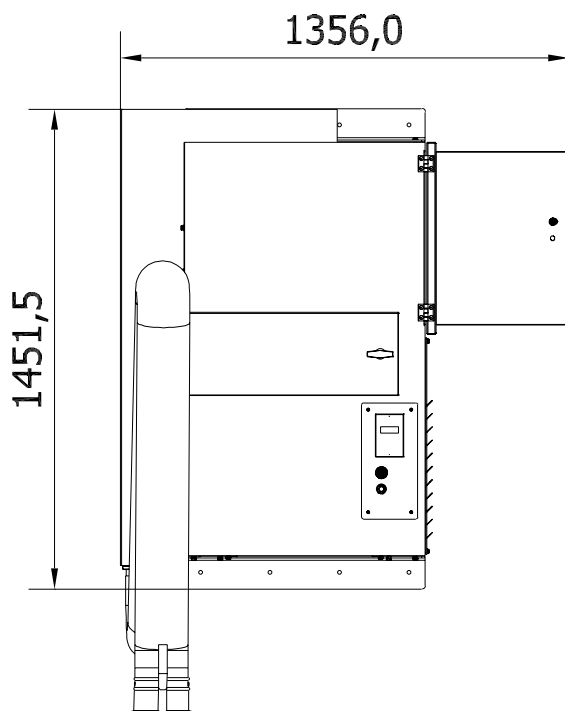

Type	Order no.	Fan	Motor [kW]	Voltage [V]	Arm type	Filter	Filter material*
SFPT1	04 243 600	VL 1150	1.10	1x230	SA 3000/ø160	1 x 21 m ²	G105
SFPT1	04 243 650	VL 1150	1.10	1x230	RGF 4000/ø160	1 x 21 m ²	G105

* Filter type: Jet filter cartridge ø325x660mm/ø13,5mm, 21m², G105 (08 128 000).
For other filter materials - see price list.

Recht auf Änderungen bleibt vorbehalten. / Data is subject to alterations.

Rev. 05/13

V. Aa. Gram A/S

LYSBJERGVEJ 10 • HAMMELEV • DK-6500 Vojens
TELEPHONE +45 74 52 30 75 • TELEFAX +45 74 53 01 64
E-MAIL: info@vaagram.dk • INTERNET: www.vaagram.com

